

Model:
CAL10A

Coldkit Calabria CAL10A
 1 Metre, Curved Glass, Ambient Patisserie Counter

Technical Drawing

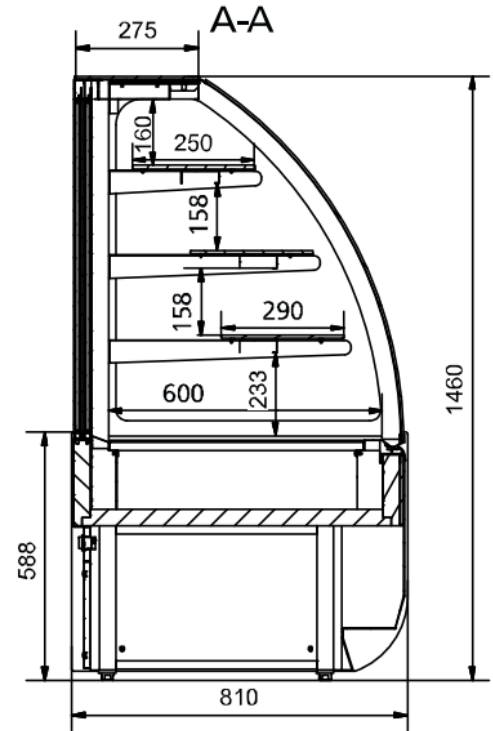

Key Features

- 4 display levels
- Stainless steel base
- Fully lit interior

Construction

- Double glazed front curved glass
- Double glazed rear doors
- Double glazed side glass
- White / stone grey finish

Available Options

- Custom colour front panels
- Wood effect front panels
- LED lighting
- Castors

Technical Data

Model	CAL10A
Display Area	1.5m ²
External Dimensions	Width = 1000 Depth = 810 Height = 1375
Interior Finish	White
Exterior Finish	Grey / White
Internal Lighting	✓
Internal Lighting Type	Fluorescent
Light switch	✓
Light switch position	Externally mounted
Temperature control	N/A
Temperature control position	N/A
Temperature range	N/A
Refrigerant	N/A



Approvals	Available At	Document #
